

WAFER SWING CHECK VALVE / 2300



PN 16
DN25 → DN400

PRODUCTION STANDARDS

DESIGN	TS EN 14341
END CONNECTION	WAFFER TYPE TS EN 1092-1 / ISO 7005-1
FACE TO FACE	TS EN 558 Seri 97
TEST	TS EN 12266-1
MARKING	TS EN 19

FEATURES

- FAF2300 Wafer type Check Valve, while allowing the flow moving to the desired flow direction, stops the flow when exposed to backflow
- The disc hinged on the body is placed within the flow section
- With the start of movement at defined flow direction on the system, the disc leaves the flow section by turning in its axis and allows the flow pass
- When the flow stops, the disc sits on the EPDM sealing rings placed on the body through disc spring force and maintains %100 tight sealing
- Deigned to maintain the minimum head loss on the pipeline
- Through its short installation length and eye screw (hook), easy to install between two flanges
- Body can be made of galvanized carbon steel (FAF2330) or stainless steel (FAF2300). Disc is made of 1.4301/AISI 304 stainless steel for both types
- Can be installed in horizontal or vertical position

APPLICATIONS

Steam, Hot Water, Cold Water, Fluids without acidity or alkalinity properties, Pressurized Air

TEMPERATURE

+130 °C

TECHNICAL DRAWING

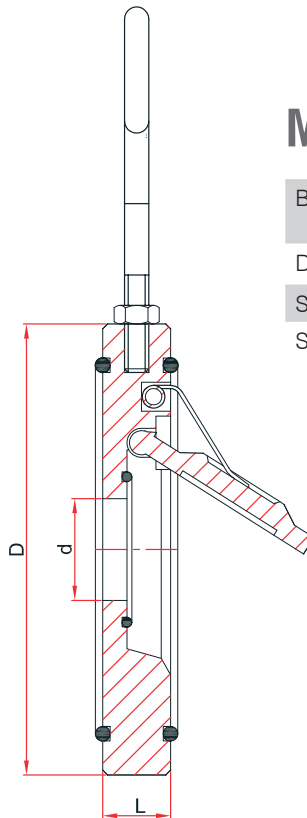
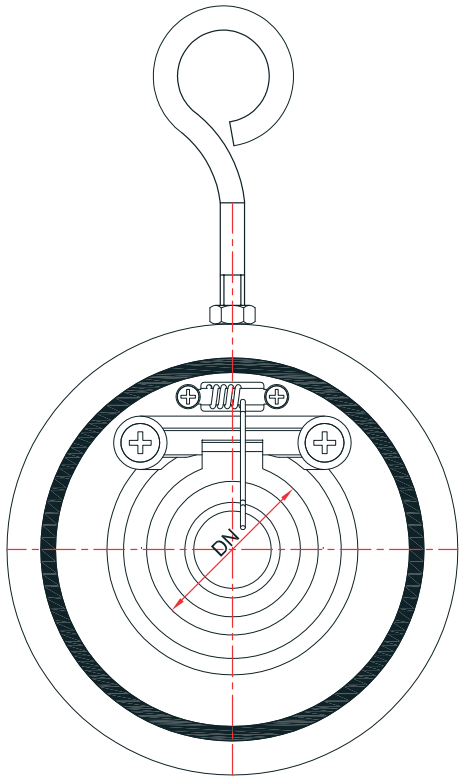

MATERIAL SELECTION

BODY	WCB CAST STEEL 1.4301 - AISI 304 STAINLESS STEEL
DISC	1.4301 - AISI 304 STAINLESS STEEL
SPRING	STAINLESS STEEL
SEALING	EPDM NBR VITON

DN mm	DIMENSION			RATINGS		STUD SIZE	BOLT/NUT QTY	FASTENING MOMENT Nm	WRENCH SIZE (mm)
	D	d	L	KV m³/h	Weight Kg				
25	71	11	14	35	0,4	M12X70	4	85	19
32	81	20	14	55	0,5	M16X75	4	205	24
40	93	23	14	88	0,7	M16X75	4	205	24
50	109	32	14	160	0,8	M16X80	4	205	24
65	129	40	14	245	1,2	M16X80	4	205	24
80	144	54	14	400	1,5	M16X90	8	205	24
100	164	70	18	615	2,3	M16X90	8	205	24
125	195	92	18	1000	3,1	M16X100	8	205	24
150	220	112	20	1500	4	M20X110	8	400	30
200	275	154	22	2350	7,5	M20X120	12	400	30
250	330	192	26	3100	13,9	M24X140	12	691	36
300	380	227	32	4000	15,8	M24X150	12	691	36
350	440	270	38	5900	25,8	M24X170	16	691	36
400	490	315	44	7500	36,3	M27X180	16	1010	41

* Valves can be produced with bigger sizes when requested.