

RUBBER EXPANSION JOINT NBR WITH SWIVELING FLANGES PN10/16 L=130mm

NBR expansion joint with swiveling flanges to absorb vibrations and noises on oil, hydrocarbon and air networks.
NBR single sphere body and floating flanges in electro galvanized carbon steel.
For linear and angular compansion.
130 mm long for all diameters.



Size : DN32 to DN200
Connection : Flanges PN10/16
Min Temperature : -10°C
Max Temperature : +80°C
Max Pressure : 16 Bars
Specifications : Absorb vibrations and noises
Linear and angular compansion
Single sphere NBR tube
Swiveling flanges

Materials : Electro galvanized steel flanges

RUBBER EXPANSION JOINT NBR WITH SWIVELING FLANGES PN10/16 L=130mm

SPECIFICATIONS :

- Absorb vibration, noises and expansion
- Linear and angular compansion
- Tube NBR (NBR marking)
- Electro galvanized steel flanges PN10/16
- Expansion limiter (option)

USE :

- Oil, hydrocarbon, air
- Min and max Temperature Ts : - 10°C to + 80°C
- Max Pressure Ps : 16 bars (see graph)

PRESSURE / TEMPERATURE GRAPH (STEAM EXCLUDED):

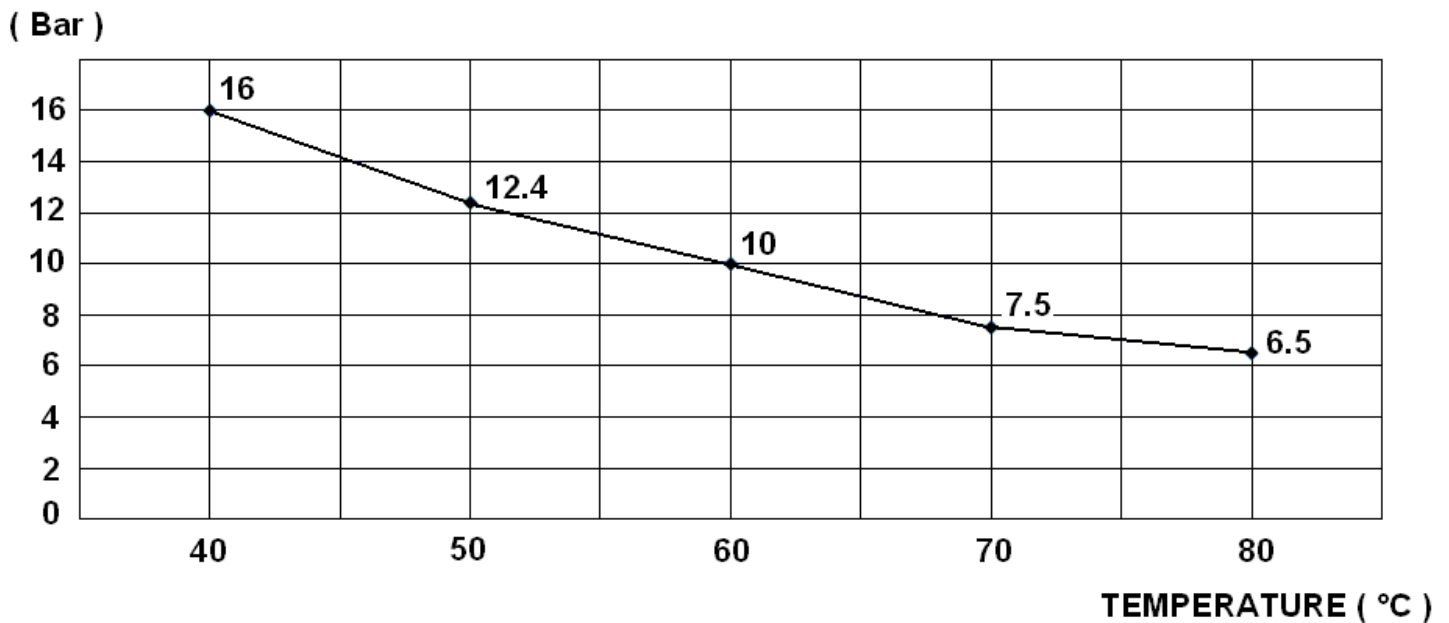

RANGE :

- NBR expansion joint 130 mm long with floating steel flanges PN10/16 from DN32 to DN150, PN10 over **Ref. 1506**
- Expansion limiter (with 2 studs and 4 plates included) from DN 32 to DN 200 **Ref. 98606**

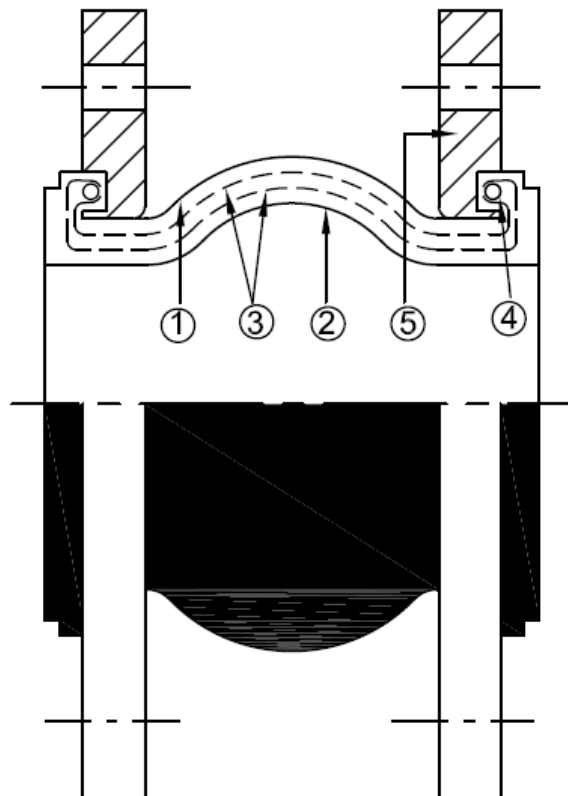
RUBBER EXPANSION JOINT NBR WITH SWIVELING FLANGES PN10/16 L=130mm
MATERIALS :

Item	Designation	Materials
1	Cover	EPDM
2	Inner tube	NBR
3	Reinforcement	Nylon cord
4	Brace	Hard steel
5	Flanges	Electro galvanized steel

RUBBER EXPANSION JOINT NBR WITH SWIVELING FLANGES PN10/16 L=130mm

SIZE (in mm) :

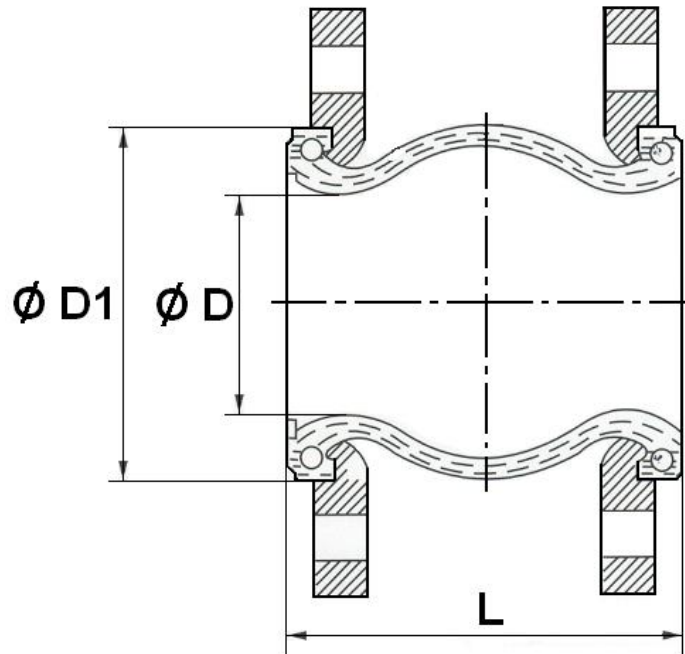

DN	32	40	50	65	80	100	125	150	200
L	130	130	130	130	130	130	130	130	130
Ø D	29	36	48	63	72	92	123	144	199
Ø D1	69	78	89	108	123	145	180	209	259
Weig. (Kg)	2.85	3.2	4.2	4.95	6	6.85	9.3	11.25	15.7
Ref.	1506032	1506040	1506050	1506065	1506080	1506100	1506125	1506150	1506200

RUBBER EXPANSION JOINT NBR WITH SWIVELING FLANGES PN10/16 L=130mm

FLANGES SIZE PN10/16 UP TO DN150, PN10 OVER (in mm) :

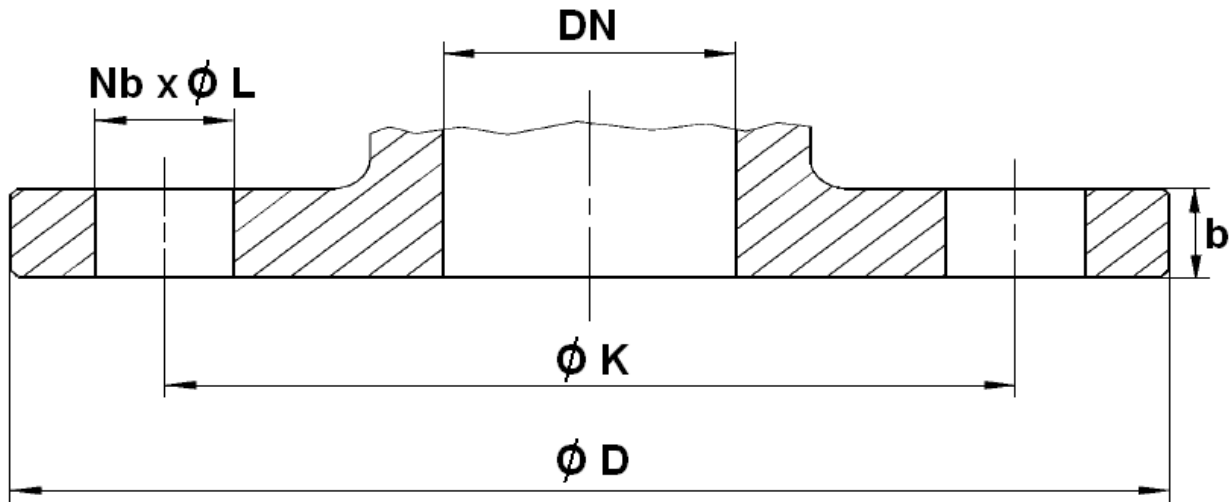

DN	32	40	50	65	80	100	125	150	200
Ø D	140	150	165	185	200	220	250	285	340
Ø K	100	110	125	145	160	180	210	240	295
Nb x Ø L	4 x 19	4 x 19	4 x 19	4 x 19	8 x 19	8 x 19	8 x 19	8 x 23	8 x 23
b	14	14	15	15	17	17	19	19	20

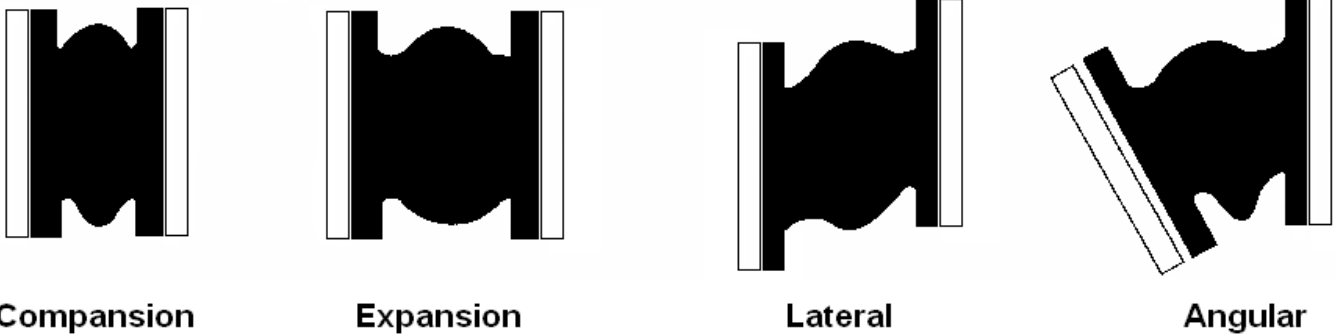
RUBBER EXPANSION JOINT NBR WITH SWIVELING FLANGES PN10/16 L=130mm
MOVEMENTS (in mm):

DN	32	40	50	65	80	100	125	150	200
Compansion	8	8	8	12	12	12	16	16	20
Expansion	4	4	4	6	6	10	10	10	14
Lateral	8	8	8	10	10	12	12	12	18
Angular	15°	15°	15°	15°	15°	15°	15°	15°	15°

Maximum movements can't be applied together

STANDARDS :

- Manufacturer certified ISO 9001 : 2015
- DIRECTIVE 2014/68/EU : Products excluded from directive (Article 4, § 3)
- Flanges according to EN 1092-1 PN10/16
- Approval certificate **Marine LLOYD'S REGISTER**

ADVICE : Our opinion and our advice are not guaranteed and SFERACO shall not be liable for the consequences of damages. The customer must check the right choice of the products with the real service conditions.

Internet: www.oktogonal.hu E-mail: szolnok@oktogonal.hu